

# KEYMIER

EST ENGLAND 1588



PREMIUM HANDMADE CLAY ROOF TILES  
Product guide





THE VYNE | Hampshire

# CONTENTS

Discover Keymer	05
Our History	07
Our Tile Range   at a glance	08
Looking for inspiration	10
Peg tiles	13
Traditional tiles	15
Shire tiles	17
Goxhill tiles	19
Ornamental tiles	21
Bespoke finials	22
Goxhill fittings	24
Keymer fittings	25
Showcasing our products	26
Keymer Heritage	32
Some projects we've worked on	34

Wienerberger Ltd 02/24 All rights reserved. Please note: Due to the limitations of the printing process and screen calibration settings when viewing the online version, you are advised to obtain product samples prior to purchase. All information contained in this brochure is believed to be correct at the time of going to press. Wienerberger reserve the right to add, delete or alter products without notice and recommend you contact us to obtain the latest information





Clockwise  
HOLY TRINITY CHURCH | KNIGHTS HAYES COURT |  
CROSBY HALL | VALLEY WAY



QUALITY, EXPERT  
CRAFTSMANSHIP  
AND CREATIVITY.

# DISCOVER KEYMER



Keymer's ambition is to inspire leading architects and homeowners like you, who want to make their mark, by providing the highest quality, premium handmade British roof tiles.

Founded in 1588, we're one of the oldest established roofing brands in the UK and have become synonymous with quality, expert craftsmanship and creativity. Our use of local, rich Wealden clay produces award winning authentic roof tiles in unique warm colours and textures, providing you with renowned durability.

Now based in Ewhurst, Surrey and owned by Wienerberger, the leading supplier of wall, roof and landscaping solutions, we continue our uncompromised artisan approach to manufacturing, using the same materials and methods as we did all those years ago.

We know the way our roof tiles are made is important to you. We continue to invest in modern progressive techniques, strengthening our commitment to fuel efficiency and a safe working environment whilst passionate about maintaining the professional skills from the past to ensure our roof tiles boast the premium quality and performance they've become famous for.

We're entering a new era for Keymer – building on our great heritage we're creating a new British history, delivering prestige roof tiles and an unrivalled specification service to both your heritage and contemporary buildings - standing out in marketplace being saturated by cheaper and less authentic imports.

We understand you're looking to make history with your designs – whether it's a modern development looking for that prestige feel or a restoration bringing a building back to its former glory, Keymer is your expert partner who can help make that happen.





# CREATING A NEW BRITISH HISTORY

## HISTORY IN THE MAKING

Keymer have been crafting beautiful handmade tiles for over 400 years. Keymer Brick & Tile Company evolved from the former Ditchling Potteries, a collection of various works including Dunstalls Farm. One of the farm's owners was John Pomfrey, who was a renowned brickmaker in Keymer in 1588.

When the Ditchling Common site was sold, having exhausted its supply of clay, production was moved to a 50-acre site on Nye Road over a period of 80 years between 1860 and 1940.

Towards the end of the 1800s, the Nye Road works were the largest in the south of England, employing 300 workers. At the turn of the century, it was famous for the manufacture of red terracotta ware – winning awards in London in 1862 and Philadelphia in 1876. This bespoke product was used throughout the British Isles and, largely due to its early success, was re-introduced by the modern-day Keymer in the 1990s.

## AN EVOLVING CRAFT

In the early days, a considerable number of Keymer workers lived in cottages on site. Further cottages were built that housed brick making tables on the ground floor with living quarters upstairs. These were commonly known as birdcages.

The site also had many tall brick chimneys, which have since been demolished to meet the requirements of the Clean Air Act. Coal, used for the drying and firing of products, was regularly delivered to the site by rail via Keymer's own siding, alongside the Lewes-Eastbourne train line. Finished products were also dispatched from

the factory using the same trains. Dr Beeching's plan to increase efficiency of the railways saw the closure of the railway sidings so natural gas replaced coal as the fuel used.

During the Second World War, the tile manufacturing works were completely closed. Buildings and kilns were used by the Admiralty for storage purposes and played a major part in the 'D-Day' landings. After the War, considerable investment was made to introduce new clay preparation machinery against a backdrop of ensuring that traditional production methods were still maintained.

## CHANGING TIMES

Due to dramatic fluctuations in the demand for bricks during the early 1970s, Keymer took the decision to stop brick manufacturing and concentrate on the production of handmade clay roofing tiles.

Architects and planners were concentrating more on the conservation and preservation of all types of buildings. This attitude gave new life to the company and resulted in the increased production of roofing tiles and fittings. In 1981, the very latest computer-controlled kilns were installed to reduce fuel consumption and provide better working conditions whilst still retaining the traditional handmaking skills. Recession in the construction industry during the 1990s led to a decline in the home market and a reduction in the production of tiles.

Since 2014, Keymer has been owned by Wienerberger, the leading supplier of wall, roof and landscaping innovations. In 2015 we made our fourth move in our 400 year history and re-launched from our new home at Wienerberger's factory in Ewhurst, Surrey.

Situated in the plain tile heartland and 20 minutes from the original site, our premium handmade clay tiles continue to be produced from the orange clays of the South Weald using the same traditional equipment and processes as it always has. We've invested heavily to ensure the handmade manufacturing process is retained, meaning that all Keymer products will boast the quality and performance they have become famous for.

## CREATING A NEW BRITISH HISTORY

Keymer still uses Wealden clay native to the area and many of the traditional craft skills, have been passed down from maker to maker through the generations.

Demand and production for Keymer's handmade clay roof tiles have shown a steady increase in recent years. Now dispatched throughout the British Isles, used on roofs from cottages to castles, supermarkets to town centres; also export to the Continent, America and lately even Russia and Japan.

Keymer continue to invest in up-to-date techniques to strengthen commitment to fuel efficiency and a safe working environment - and, at the same time, to manufacture the finest genuine hand made clay roofing products.

# OUR TILE RANGE AT A GLANCE



## PEG TILES



Weathered (County)



Antique (Kent)



## TRADITIONAL



Antique



Wealden Red



Elizabethan



## SHIRE



Heritage



Downs Red



Priory



## GOXHILL



Autumn Brown



Dark Red



Dark Chestnut

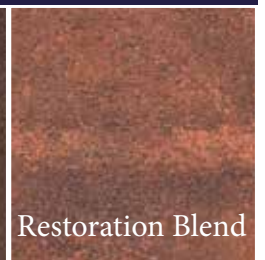

Restoration Blend





# LOOKING FOR INSPIRATION?

Be inspired by the very best roof architecture created using our market-leading range of roof tiles and roofing systems.

Discover roof design ideas for your next project, with our beautiful range of roof project examples, from small-scale installations to complex, bespoke designs, and everything in between.

Throughout this brochure we'll be showcasing stunning roof architecture, from complete renovations of historic landmarks with handmade clay tiles, to award-winning modern homes that push the envelope of what can be done with roofing. Past projects include stunning stately homes, modern luxury residential developments, social housing, commercial projects and more.

Our portfolio of roofing products is the largest in the UK, including bespoke solutions from our Keymer Heritage team and a full range of roof systems and accessories. See how developments across the UK have used our roofing products to deliver unrivalled performance and aesthetics with our collection of projects.



## PROJECT DETAILS

---

Clockwise from top left  
Private house | DIDSBURY  
BRADFIELD COLLEGE | Reading  
Private house | ARTS & CRAFTS HOUSE  
THE OLD BARN | Rusper  
CHURCHILL COLLEGE | Cambridge





# DELIVERING PRESTIGE HANDMADE CLAY ROOF TILES



SHAKESPEARE'S BIRTHPLACE TRUST |  
Stratford upon Avon

INNOVATIVE  
IN DESIGN.



# PEG TILES



## County Peg - Weathered

Our County peg tiles are innovative in design. They are created for renovation use, with three nail holes and one nib, to make fitting easier and less disruptive. These tiles are the ideal choice for the refurbishment of older peg tiled buildings or for use on oast houses.



## Kent Peg - Antique

Our Kent peg tiles are Britain's best peg tiles, handmade by craftsmen using the company's rich Wealden Clay. They are better and more cost effective than using second hand tiles which can quickly deteriorate once stripped off and re-used.



## TECHNICAL INFORMATION

	County Single Nib	Kent Nibless
Size of tile <sup>1</sup>	250x150mm	250x150mm
Colours available	Weathered	Antique
Minimum roof pitch	40°	40°
Covering capacity	70.2 tiles per m <sup>2</sup>	70.2 tiles per m <sup>2</sup>
Batten spacing (fixed gauge) <sup>1</sup>	95mm	95mm
Weight per tile	1.2kg	1.2kg
Weight as laid	84.3kg per m <sup>2</sup>	84.3kg per m <sup>2</sup>
Weight per 1,000 (inc pallet & packaging)	1.24 tonnes	1.24 tonnes
Pallet quantity	760	760
Pallet weight	0.939 tonnes	0.939 tonnes

<sup>1</sup>Clay tiles are subject to small variations in size because of drying and firing shrinkage in the manufacturing process. Before deciding on the batten gauge and linear coverage, the roof tiler should inspect each batch of tiles to ensure that the correct minimum headlap and sidelap are achieved. Unless otherwise stated, data is based on the tiles laid at minimum headlap.

OUR  
PRODUCTS



THE VYNE | Hampshire

QUALITY  
CRAFTSMANSHIP.

PAGE | 14



# TRADITIONAL TILES



Our traditional clay plain tiles are hand made using Weald Clay. The rich reds of the clay give them their deep natural colour. The tiles do not all sit flat next to each other in total conformity but in gentle undulations reminiscent of a centuries old cottage.



Antique



Wealden Red



Elizabethan

## TECHNICAL INFORMATION

	Traditional
Size of tile <sup>1</sup>	265x165mm
Colours available	Antique Wealden Red Elizabethan
Minimum roof pitch	40°
Covering capacity	60 tiles per m <sup>2</sup>
Batten spacing (fixed gauge) <sup>1</sup>	100mm
Weight per tile	1.22kg
Weight as laid	73.2kg per m <sup>2</sup>
Weight per 1,000 (inc pallet & packaging)	1.3 tonnes
Pallet quantity	760
Pallet weight	0.988 tonnes

<sup>1</sup>Clay tiles are subject to small variations in size because of drying and firing shrinkage in the manufacturing process. Before deciding on the batten gauge and linear coverage, the roof tiler should inspect each batch of tiles to ensure that the correct minimum headlap and sidelap are achieved. Unless otherwise stated, data is based on the tiles laid at minimum headlap.



PLAISTOW

INNOVATIVE  
IN DESIGN.





# SHIRE TILES



A genuine handmade British clay tile that offers a serious alternative to the traditional style of clay roof tiles. Produced in three colours, every tile weathers naturally to look better and improve with every passing year.

Heritage

Downs Red

Priory

## TECHNICAL INFORMATION

	Shire
Size of tile <sup>1</sup>	265x165mm
Colours available	Heritage Downs Red Priory
Minimum roof pitch	40°
Covering capacity	60 tiles per m <sup>2</sup>
Batten spacing (fixed gauge) <sup>1</sup>	100mm
Weight per tile	1.22kg
Weight as laid	73.2kg per m <sup>2</sup>
Weight per 1,000 (inc pallet & packaging)	1.3 tonnes
Pallet quantity	550
Pallet weight	0.715 tonnes

<sup>1</sup>Clay tiles are subject to small variations in size because of drying and firing shrinkage in the manufacturing process. Before deciding on the batten gauge and linear coverage, the roof tiler should inspect each batch of tiles to ensure that the correct minimum headlap and sidelap are achieved. Unless otherwise stated, data is based on the tiles laid at minimum headlap.



THE RECTORY |

QUALITY  
CRAFTSMANSHIP.



# GOXHILL TILES



The Keymer Goxhill range of tiles is one of the finest and most distinctive roof coverings available. This handmade plain tile gives a rich textured roofscape that will become more and more attractive with age.

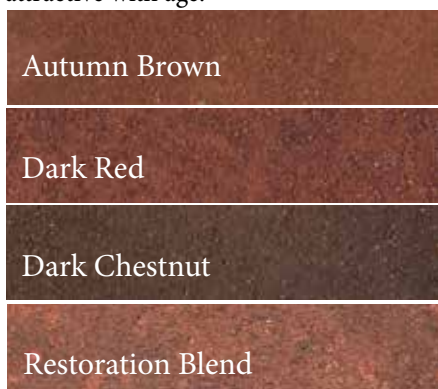

## TECHNICAL INFORMATION

	Roof	Vertical
Size of tile <sup>1</sup>	265x165mm	265x165mm
Colours available	Autumn Brown Dark Red Dark Chestnut	Autumn Brown Dark Red Dark Chestnut
Minimum roof pitch	35°	75°
Covering capacity	60.0 tiles per m <sup>2</sup>	53.0 tiles per m <sup>2</sup>
Batten spacing (fixed gauge) <sup>1</sup>	100mm	114mm
Weight per tile	1.21kg	1.21kg
Weight as laid	72.6kg per m <sup>2</sup>	64.2kg per m <sup>2</sup>
Weight per 1,000 (inc pallet & packaging)	1.31 tonnes	1.31 tonnes
Pallet quantity	540	540
Pallet weight	0.707 tonnes	0.707 tonnes

<sup>1</sup>Clay tiles are subject to small variations in size because of drying and firing shrinkage in the manufacturing process. Before deciding on the batten gauge and linear coverage, the roof tiler should inspect each batch of tiles to ensure that the correct minimum headlap and sidelap are achieved. Unless otherwise stated, data is based on the tiles laid at minimum headlap.



SHIREBURN ROAD |

INNOVATIVE  
IN DESIGN.



# ORNAMENTAL TILES



Club

Diamond

Arrowhead<sup>2</sup>

Bullnose

Since handmade clay tiles first went into production, their makers recognised that special design could set a roof or clad wall apart from the rest - enhancing the building in looks as well as worth.

To ensure compatibility with all Keymer products, the range of ornamental tiles can be made to order in all the standard colours

Keymer can also make ornamental tiles to individual specification - whether for matching or to realise an original concept.

Because all these products have the same renowned Keymer weathering properties, they soon blend in with existing materials for renovation work looking better and lasting longer.

<sup>2</sup>We've updated some of our ornamental tiles product names. Diamond was previously known as Arrow and Arrowhead was previously known as Point.

## TECHNICAL INFORMATION

	Club	Diamond	Arrowhead	Bullnose
Size of tile <sup>1</sup>	265x165mm	265x165mm	265x165mm	265x165mm
Minimum roof pitch	40°	40°	40°	40°
Covering capacity	60 tiles per m <sup>2</sup>	60 tiles per m <sup>2</sup>	60 tiles per m <sup>2</sup>	60 tiles per m <sup>2</sup>
Batten spacing (fixed gauge) <sup>1</sup>	100mm	100mm	100mm	100mm
Weight per tile	1.22kg	1.22kg	1.22kg	1.22kg
Weight as laid	73.2kg per m <sup>2</sup>	73.2kg per m <sup>2</sup>	73.2kg per m <sup>2</sup>	73.2kg per m <sup>2</sup>
Weight per 1,000 (inc pallet & packaging)	1.3 tonnes	1.3 tonnes	1.3 tonnes	1.3 tonnes
Pallet quantity	550	550	550	550
Pallet weight	0.715 tonnes	0.715 tonnes	0.715 tonnes	0.715 tonnes

<sup>1</sup>Clay tiles are subject to small variations in size because of drying and firing shrinkage in the manufacturing process. Before deciding on the batten gauge and linear coverage, the roof tiler should inspect each batch of tiles to ensure that the correct minimum headlap and sidelap are achieved. Unless otherwise stated, data is based on the tiles laid at minimum headlap.



# KEYMER

BESPOKE

## BESPOKE FINIALS

made to order

OUR EXPERTISE MEANS THAT ANYTHING CAN BE MADE IN CLAY TO SUIT THE NEEDS OF ANY PROJECT, WHETHER TO MATCH AN AUTHENTIC PIECE OR FULFIL A NEW SPECIFICATION.





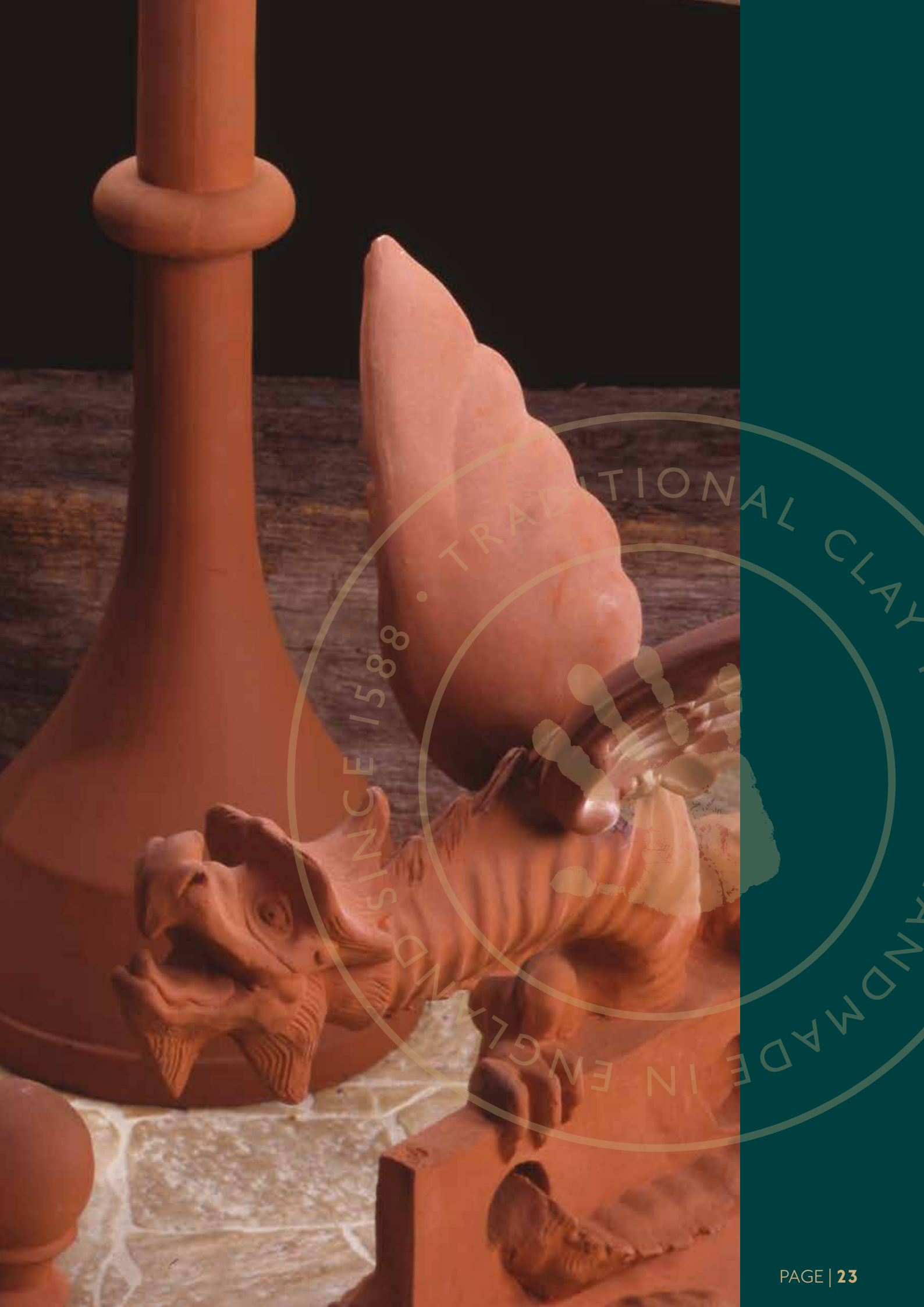



EACH ITEM IS INDIVIDUALLY MADE BY HAND USING WEALDEN CLAY FROM KEYMER'S OWN SOURCES.

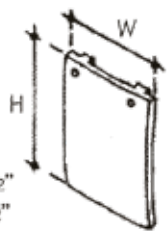

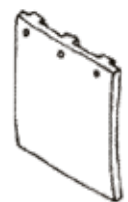
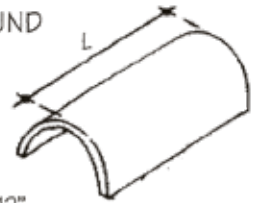

SINCE 1588 • TRADITIONAL CLAY  
HANDMADE IN ENGLAND

# GOXHILL FITTINGS











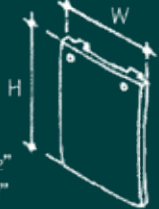







<p>PLAIN TILE</p>  <p>H. 265 H. 10 1/2" W. 165 W. 6 1/2"</p>	<p>EAVES TILE</p>  <p>H. 200 H. 8" W. 165 W. 6 1/2"</p>	<p>GABLE TILE</p>  <p>H. 265 H. 10 1/2" W. 248 W. 10"</p>
<p>HALF ROUND</p>  <p>L. 305 L. 12"</p>	<p>HOGBACK</p>  <p>L. 305 L. 12"</p>	<p>THIRD ROUND</p>  <p>L. 305 L. 12"</p>
<p>STANDARD BONNET</p> <p>35-50 SLOPE 5:12 - 6:12</p> 	<p>VERTICAL ANGLE 90° (HANDED)</p>  <p>EXTERNAL</p>	<p>VERTICAL BAY ANGLE 135° (HANDED)</p>  <p>EXTERNAL</p>

\*Also available in: Baby Ridge, InvisiVent, Valley Tile, Arris Hip and Monopitch Ridge

KEYMER MANUFACTURE THE LARGEST RANGE OF HANDMADE CLAY FITTINGS YOU'LL FIND. THE TRUE SKILL OF THE KEYMER MASTER TILE MAKER IS WELL DISPLAYED, FROM THE VALLEY TO THE RIDGE. USING ALLUVIAL CLAY FOR GOXHILL AND WEALDEN CLAY FOR KEYMER, THESE FITTINGS ARE NOT ONLY THE NATURAL CHOICE IN CONSERVATION AREAS BUT ALSO ADD CHARACTER AND VALUE TO ANY NEW BUILDING TOO.



# KEYMER FITTINGS

<p><b>PLAIN TILE</b></p>  <p>H. 265 H. 10 1/2" W. 165 W. 6 1/2"</p>	<p><b>EAVES TILE</b></p>  <p>H. 200 H. 8" W. 165 W. 6 1/2"</p>	<p><b>GABLE TILE</b></p>  <p>H. 265 H. 10 1/2" W. 248 W. 10"</p>	<b>PLAIN TILES</b>
<p><b>PEG TILE (KENT or COUNTY)</b></p>  <p>H. 250 H. 10" W. 150 W. 6"</p>	<p><b>PEG EAVES</b></p>  <p>H. 150 H. 6" W. 150 W. 6"</p>	<p><b>PEG GABLE</b></p>  <p>H. 250 H. 10" W. 225 W. 9"</p>	
<p><b>HALF ROUND</b></p>  <p>L. 305 L. 12"</p>	<p><b>HOGBACK</b></p>  <p>L. 305 L. 12"</p>	<p><b>THIRD ROUND</b></p>  <p>L. 305 L. 12"</p>	<b>RIDGE TILES</b>
<p><b>STANDARD BONNET</b></p> <p>40-50 SLOPE 5:12 - 6:12</p> 	<p><b>TRADITIONAL BONNET</b></p> <p>40-45 SLOPE 5:12</p> 	<p><b>KENT BONNET</b></p> <p>50-60 SLOPE 6:12 - 7:12</p> 	
<p><b>STANDARD VALLEY</b></p> <p>40-50 SLOPE 5:12 - 6:12</p> 	<p><b>GULL WING VALLEY (CAMBERED)</b></p> <p>40-45 SLOPE 5:12</p> 	<p><b>60° VALLEY</b></p> <p>50-60 SLOPE 6:12 - 7:12</p> 	<b>VALLEY TILES</b>
<p><b>MONOPITCH RIDGE</b></p>  <p>L. 305 L. 12"</p>	<p><b>PORCH RIDGE</b></p>  <p>L. 305 L. 12"</p>		
<p><b>VERTICAL ANGLE 90° (HANDED)</b></p>  <p>EXTERNAL</p>	<p><b>VERTICAL BAY ANGLE 135° (HANDED)</b></p>  <p>EXTERNAL</p>		

# Aesthetic ambitions and practical needs

**Caring Wood** is an extensive country home project set in 84 acres of scenic Kentish countryside designed by architects James Macdonald Wright and Niall Maxwell. It is a magnificent country home with the space for three generations of the same family, incorporating formal, communal and private spaces.

The architects chose the **Keymer County Peg Antique tile** for two reasons. Firstly, they liked the natural aesthetic, which is imbued with a distinctive finish and warmth of colour thanks to Keymer's use of rich Wealdon Clay. And secondly, the design made handling and laying a simple and easy process for contractors. The architects were meticulous in their detailing and planning and so were attracted to working with the Keymer team because of their dedicated and flexible service.

The 153,000 Keymer County Peg Antique tiles added together to create a striking looking roof for the country home. The tiles were gradually delivered throughout each stage of the project and were produced using the traditional handmade techniques over a period of a year.



## PROJECT DETAILS

**Caring Wood, Kent**

Client: **Private**

Design and Project

Management Architect:

**Macdonald Wright  
Architects**

Executive Architect: **Rural**

**Office for Architecture**

Contractors: **Complete  
Roofing Contractors**



CARING WOOD | Kent



OFFERING A  
DEDICATED AND  
FLEXIBLE SERVICE





DOKETT BUILDING | Queens' College, Cambridge



UNMATCHED  
QUALITY.



# A natural choice for the roof replacement



**The Dokett Building** is a site steeped in academic history, named after the first President of Queens' College, Andrew Dokett. This magnificent building is a prominent element of the college's architecture, it can even be seen from the opposite side of the campus. The Dokett Building provides accommodation for the college's students, featuring 34 study bedrooms, 12 kitchens and a Fellows' room.

The roofing contractors were tasked with stripping and re-covering the entire 100-year-old roof. One of the main reasons the roof needed replacing was that it hadn't been updated in decades. The accommodation needed to be drastically modernised, so new dormers were created to allow for ventilation and new bathrooms.

Due to the prominent location of the building on campus, and it being of historical local interest, **Keymer's handmade Traditional Antique and Elizabethan tiles** were selected to ensure a sympathetic renovation that was in keeping with the existing building design principles of Queens' College. As well as providing Traditional Keymer tiles, the Keymer team manufactured 450 bespoke hips tile for all the new and existing dormer roofs.



## PROJECT DETAILS

**Dokett Building, Queens College**

Client: **University of Cambridge**

Architect: **BB+C Architects Limited**

Contractors: **GHB Roofing Ltd**

# The use of beautiful heritage products

Award-winning and experienced renovator Tim Pitt chose **Keymer's Traditional Elizabethan and Antique tiles** to reroof his Grade 2 listed property in Suffolk, with the aim of keeping its historic integrity whilst creating a comfortable and insulated family home. The appearance of the sympathetically renovated roof complements the building beautifully and is much admired by the local community.

Due to the Grade 2 status of the property, it was essential to the success of the reroofing stage that the tiles chosen fitted in with the overall character and quality of the building. By selecting a 50/50 mix of Keymer's Traditional Elizabethan and Antique tiles, the period property now boasts the use of beautiful handmade heritage products, which the home owner believed were the closest match to the peg tiles expected to be seen on a house of this period and location. They are considered by the owner to be a very significant improvement on the machine-made plain tiles that had previously been slipping and falling from the roof.

Tim and his family now enjoy a stunning period home, which is comfortable and efficient to run - holding an even temperature both in Summer and Winter. The quality and durability of the tiles used for the renovation means that the roof should remain beautiful and watertight for decades to come.





THE OLD VICARAGE | Suffolk



A UNIQUE AESTHETIC  
WITH TRUE HERITAGE



# KEYMIER

## HERITAGE

THE WIENERBERGER HERITAGE SERVICE IS A SPECIALIST CONSERVATION AND RESTORATION SERVICE THAT CREATES BESPOKE HANDMADE ROOF TILES AND FITTINGS.

From cottages and barns to stately homes, many of our older buildings offer a profusion of detail that, today, would be deemed an architectural luxury. Over the centuries, the use of roofing material has varied from place to place, with a diversity determined by local geography and material availability.

One of the most enduring and appealing of these materials was natural clay; which became desirable for its mellow appearance and weathering properties. Its popularity as a roof covering was enhanced by its unique ability to be pressed into a multitude of shapes and designs.

This enabled past designers to create an endless landscape of decorative roofs through the inclusion of ornate finials, ridges and hips. Builders in the 17–19th centuries in particular placed great emphasis on appearance and detail and strove to add character to their work.

Family homes that would be passed down through generations were often constructed to include bespoke features that reflected the occupants' tastes or even personal wealth. Individuality within a style in keeping with the overall local vernacular was of paramount importance.



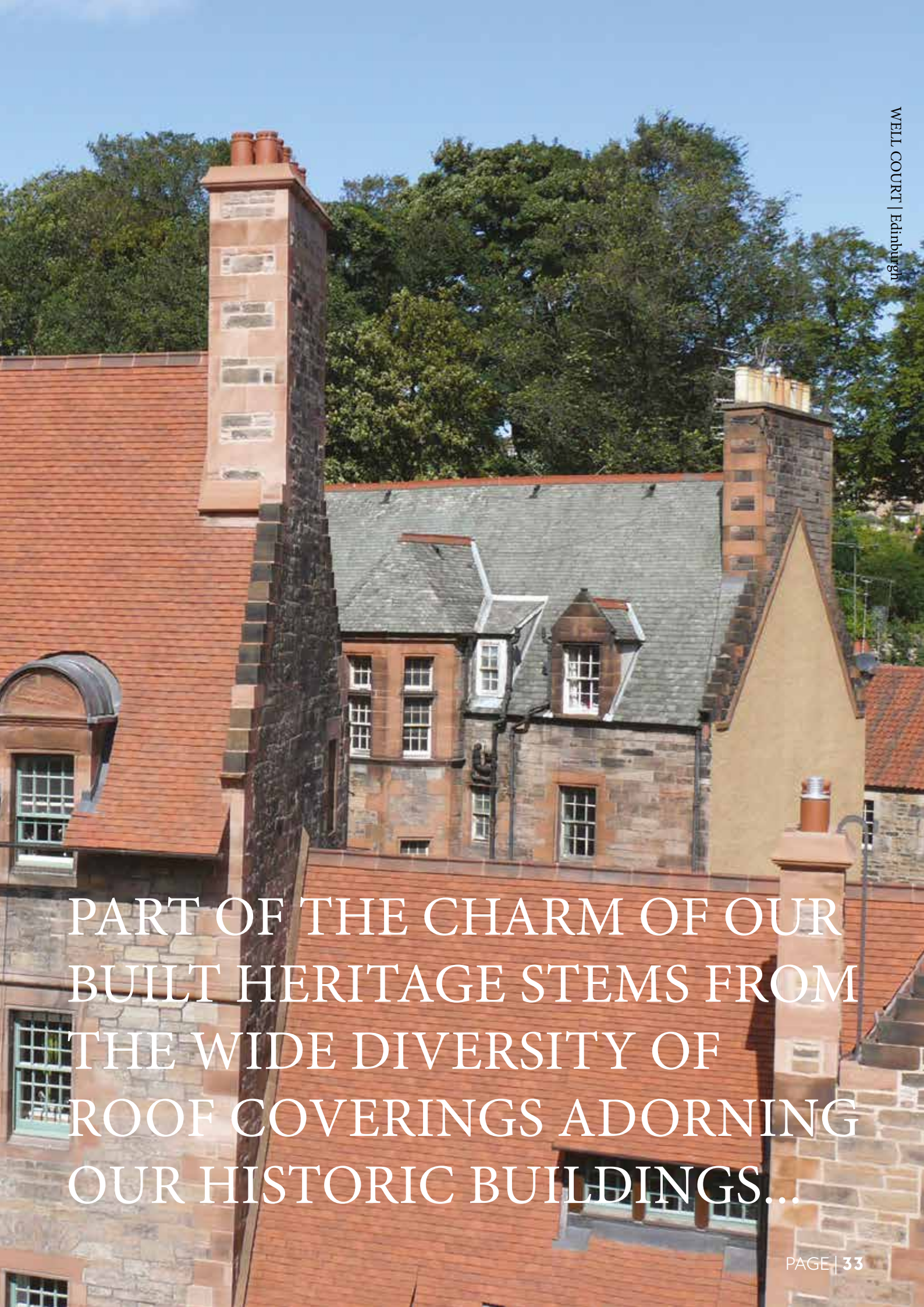

PART OF THE CHARM OF OUR  
BUILT HERITAGE STEMS FROM  
THE WIDE DIVERSITY OF  
ROOF COVERINGS ADORNING  
OUR HISTORIC BUILDINGS...



# FINALLY...

Here are some of the past projects we've been involved with

## ROYAL HOUSEHOLDS

Windsor Castle  
Kensington Palace  
St James's Palace  
Hampton Court Apartments

## RELIGIOUS BUILDINGS

St Pauls Cathedral, the Deanery  
All Saints Church, Ongar  
Choir House, Canterbury Cathedral  
St Thomas Church, Brentwood  
St Mary's Church, Rickingham  
Portsmouth Cathedral  
Ely Cathedral  
Tewkesbury Abbey  
Bradwell Abbey  
Douai Abbey, Berkshire  
Blendworth Church, Hampshire  
Caldey Island Monastery  
Dunwich St James, Suffolk  
Golders Green Crematorium  
Our Lady Queen of Martyr's, Chideok  
William Booth College, London  
Rosslyn Chapel, Roslin  
St Columba's Church, Glasgow

## NATIONAL TRUST / ENGLISH HERITAGE

Dover Castle, Kent  
The Vyne, Basingstoke  
Bodiam Castle, East Grinstead  
Scotney Castle, East Sussex  
Critchley Hall, Buckinghamshire  
Harvington Hall, Worcestershire  
Hever Castle, Kent  
Ightham Mote, Kent  
Michelham Priory, East Sussex  
Leeds Castle, Kent  
Watts Chapel, Surrey  
Chartwell, Kent  
Cliffords Tower, York  
Oxborough Hall, Norfolk  
Shakespeare's Birthplace,  
Stratford-on-Avon  
Tyntesfield, Somerset  
Welbeck Estate, Notts

## PUBLIC & HISTORICAL BUILDINGS

Jane Austen's House, Hampshire  
Thames Hospice, Maidenhead  
Tonbridge Castle, Kent  
County Hall, London  
The Tower of London  
Market Cross, Wymondham

Shakespeare's Birthplace Trust  
Lord Leycester Hospital, Warwick  
Cobtree Museum,  
Weald & Downland Museum, Sussex  
Leatherhead Town Hall, Surrey  
Reading Town Hall  
Bournville Village, West Midlands  
Zoological Museum, Hertfordshire  
Bursledon Brickworks Museum,  
Hampshire  
Goodwood Estate  
West Boathouse, Glasgow Green  
Boston Guildhall, Lincolnshire  
Mawley Hall, Shropshire  
Ashby Hall, Lincolnshire  
Cawood Castle, North Yorkshire  
Cliveden House, Berkshire  
Ednaston Manor, Derbyshire  
Finsbury Circus Pavilion  
Fountains Abbey, North Yorkshire  
Halnacker Windmill, Sussex  
India Building, Liverpool  
Middle Temple Hall, London  
The Old Curiosity Shop, London  
Queensbury House, Edinburgh  
Well Court, Edinburgh  
Reform Club, Pall Mall  
Saffron Walden Town Hall  
Stonor Park, Berkshire  
The Burge, Coventry  
The Old Courthouse, Worcs  
Verulamium Museum, St Albans  
Villa Urbana, Wroxeter  
The Rectory, Frome

## EDUCATIONAL BUILDINGS

Sevenoaks School – new girls and boys  
boarding houses.  
Ibstock Place School Refectory  
Brentwood School  
Churchill College, Cambridge  
Queens College, Cambridge  
Farnborough Hill College  
Kings College, Cambridge  
Oxford University  
Duke of York Military School, Dover, Kent  
Clare College, Cambridge  
Cambridge University Library  
Eton College  
Merchant Taylors School, Middlesex  
Sawston School, Cambridge  
University of Manchester  
Fylingdale School, North Yorkshire



## Sponsorships

### English Heritage – Corporate Partnership

Conservation in Action interpretation programme at Dover Castle 2021 – 2022

### Historic England – Heritage Angels Awards 2018

Sponsor of Best Rescue of a Historic Building or Place (projects under £5 million)

Winner | The Florence Institute, Liverpool

### Society for the Protection of Ancient Buildings (SPAB) – Heritage Award

Sponsors of Sustainable Heritage Category 2022

Winner | No.4, Black Bull Close – the rescue of an abandoned 18th-century building behind Dunbar High Street, by community-based charity the Ridge

## Recent Awards

### Pitched Roofing Awards 2022

Best Use of a Heritage Roof | Jane Austen’s House with Clarke Roofing Southern Ltd

### 2017 Grand Designs RIBA House of the Year

Caring Wood

### RIBA National Award 2022

### RIBA Regional London Award 2022

### AJ Awards - School category 2021

Ibstock Place School Refectory by Maccreanor Lavington

### RIBA Regional Southeast Award 2022

Aisher House Sevenoaks School, Kent by Tim Ronalds Architects’

### RIBA Regional South Award 2022

### AJ Awards - Health and Wellbeing category 2022

Thames Hospice, Maidenhead, by KKE Architects

### RIBA Regional East Award 2022

Churchill College, Cambridge, by Cottrell & Vermeulen

### RICS Award 2018 (Finalist)

### AJ Specification Award 2019 (Finalist)

Grevel Lane – Arts & Crafts House with Design Storey Architects

### RIAI Universal Design Award 2022

### RICS Awards 2022 - Refurbishment/Revitalisation Project

India Buildings, Liverpool





# Wienerberger

## Wall Solutions

-  **Terca**
-  **Porotherm**
-  **Corium**
-  **SVK**

## Roof Solutions

-  **Sandtoft**
-  **Koramic**
- KEYMER**

## Landscaping Solutions

-  **Penter**

For further information please contact the Keymer team on  
01444 232931 | [info@keymer.co.uk](mailto:info@keymer.co.uk)

[keymer.co.uk](http://keymer.co.uk)    

# KEYMER

EST ENGLAND 1588